

Red Black Trees

Top-Down Deletion

Recall the rules for BST deletion

1. If vertex to be deleted is a leaf, just delete it.
2. If vertex to be deleted has just one child, replace it with that child
3. If vertex to be deleted has two children, replace the value of by it's in-order predecessor's value then delete the in-order predecessor (a recursive step)

What can go wrong?

1. If the delete node is red?

Not a problem – no RB properties violated

2. If the deleted node is black?

If the node is not the root, deleting it will change the black-height along some path

The goal of T-D Deletion

- To delete a red leaf
- How do we ensure that's what happens?
 - As we traverse the tree looking for the leaf to delete, we change every node we encounter to red.
 - If this causes a violation of the RB properties, we fix it

Bottom-Up vs. Top-Down

- Bottom-Up is recursive
 - BST deletion going down the tree (winding up the recursion)
 - Fixing the RB properties coming back up the tree (unwinding the recursion)
- Top-Down is iterative
 - Restructure the tree on the way down so we don't have to go back up

Terminology

- Matching Weiss text section 12.2
 - X is the node being examined
 - T is X's sibling
 - P is X's (and T's) parent
 - R is T's right child
 - L is T's left child
- This discussion assumes X is the left child of P. As usual, there are left-right symmetric cases.

Basic Strategy

- As we traverse the tree, we change every node we visit, X , to Red.
- When we change X to Red, we know
 - P is also Red (we just came from there)
 - T is black (since P is Red, it's children are Black)

Step 1 – Examine the root

1. If both of the root's children are Black
 - a. Make the root Red
 - b. Move X to the appropriate child of the root
 - c. Proceed to step 2
2. Otherwise designate the root as X and proceed to step 2B.

Step 2 – the main case

As we traverse down the tree, we continually encounter this situation until we reach the node to be deleted

X is Black, P is Red, T is Black

We are going to color X Red, then recolor other nodes and possibly do rotation(s) based on the color of X's and T's children

2A. X has 2 Black children

2B. X has at least one Red child

Case 2A

X has two Black Children

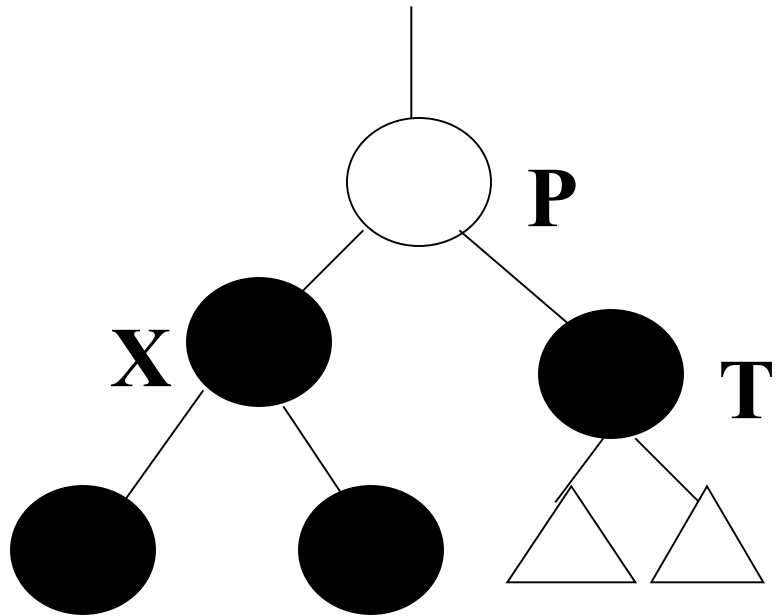

2A1. T has 2 Black Children

2A2. T's left child is Red

2A3. T's right child is Red

** if both of T's children are Red,
we can do either 2A2 or 2A3

Case 2A1

X and T have 2 Black Children

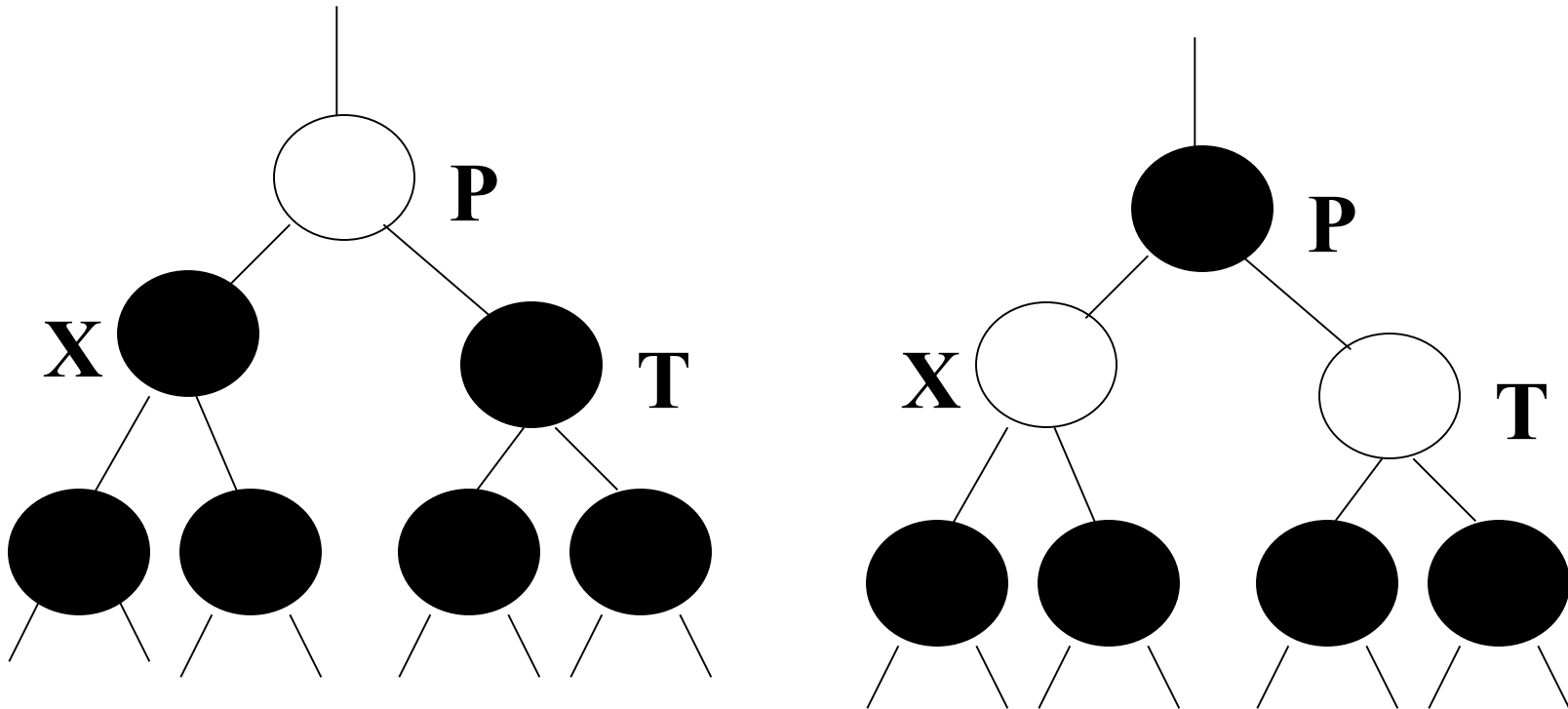

Just recolor X, P and T and move down the tree

Case 2A2

X has 2 Black Children and T's Left Child is Red

Rotate L around T, then L around P

Recolor X and P then continue down the tree

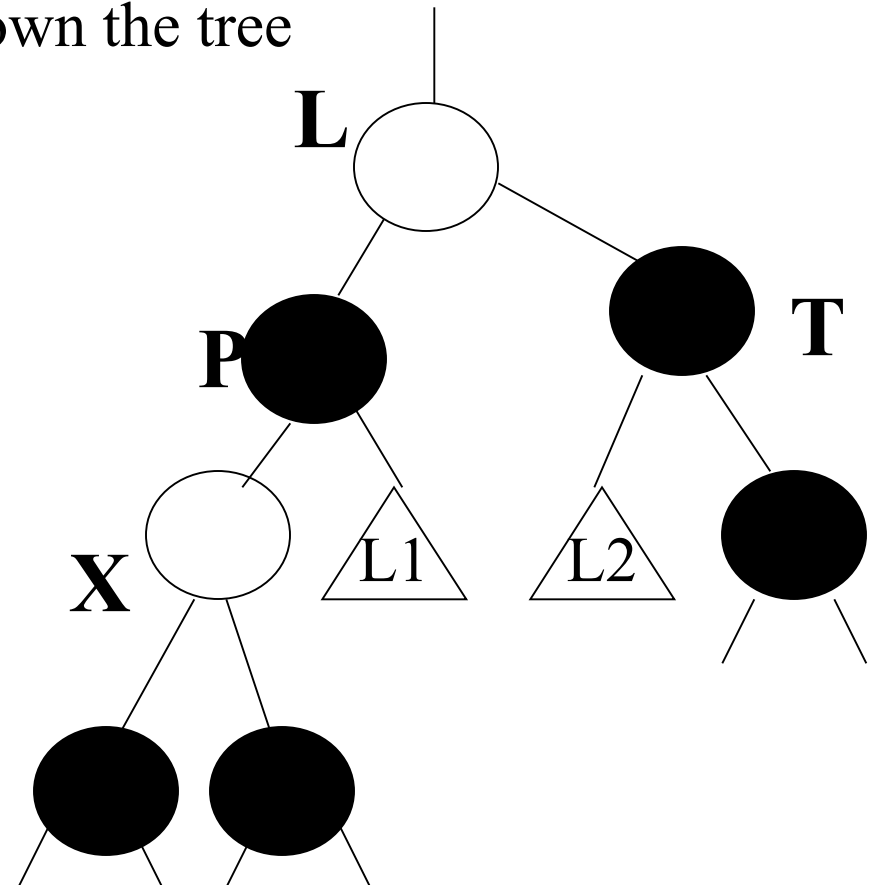
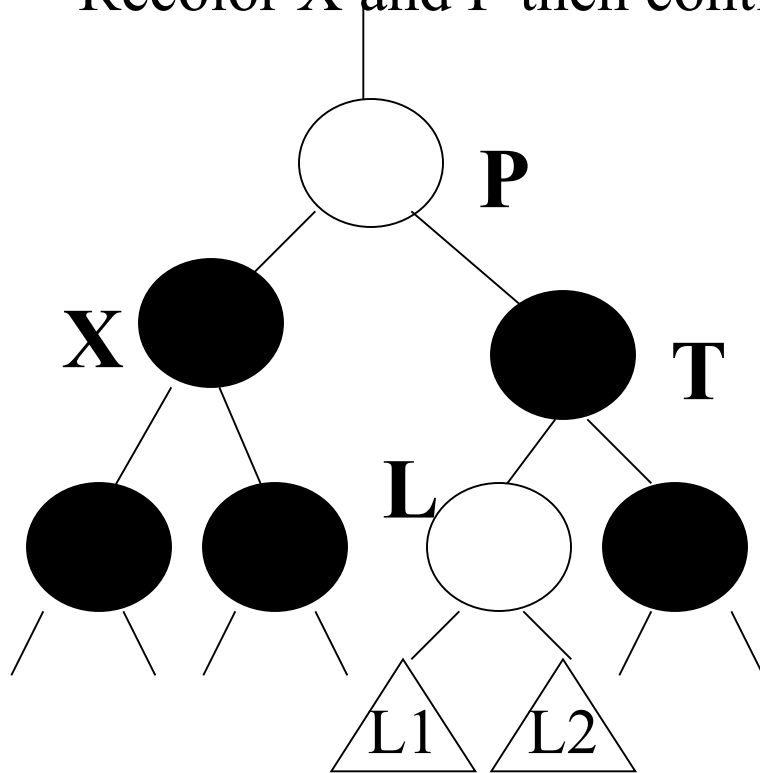

Case 2A3

X has 2 Black Children and T's Right Child is Red

Rotate T around P

Recolor X, P, T and R then continue down the tree

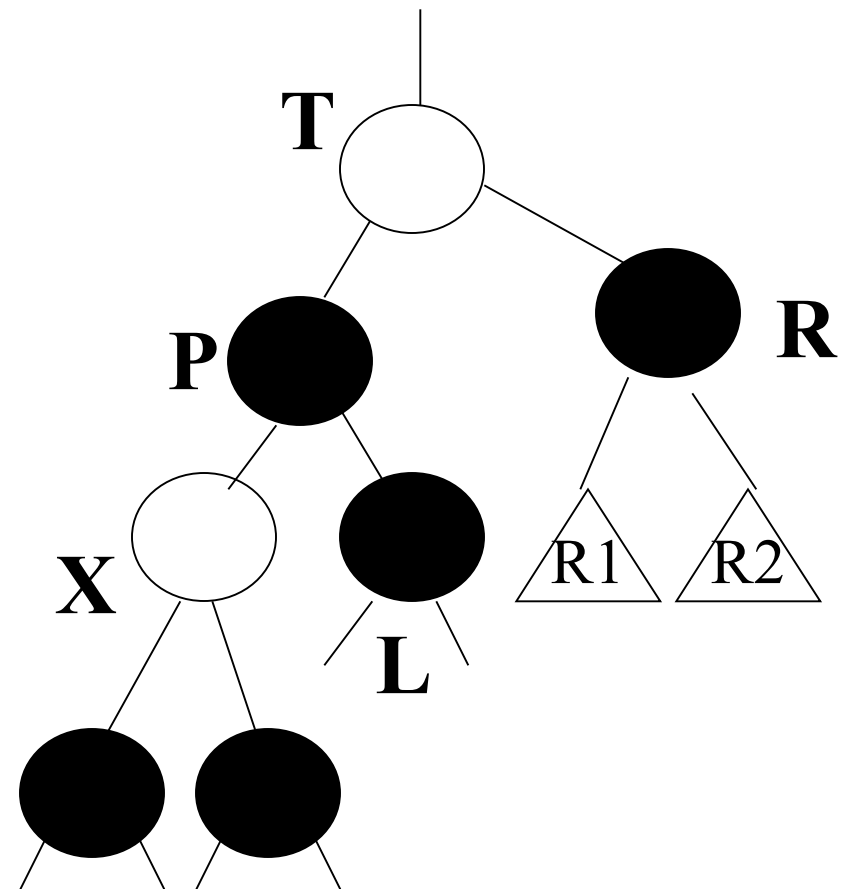
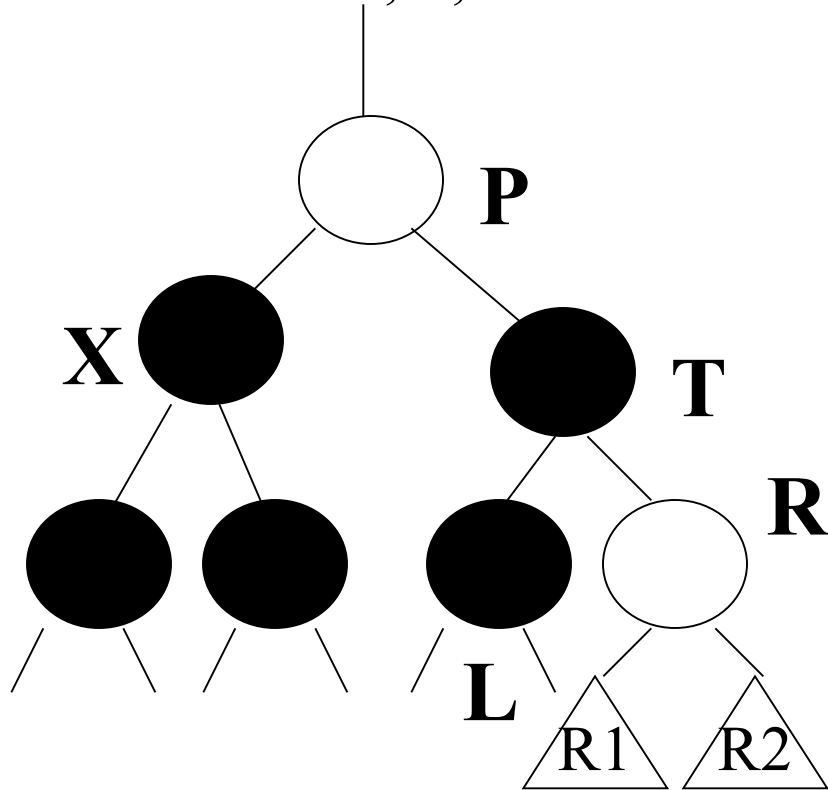

Case 2B

X has at least one Red child

Continue down the tree to the next level

If the new X is Red, continue down again

If the new X is Black (T is Red, P is Black)

Rotate T around P

Recolor P and T

Back to main case – step 2

Case 2B Diagram

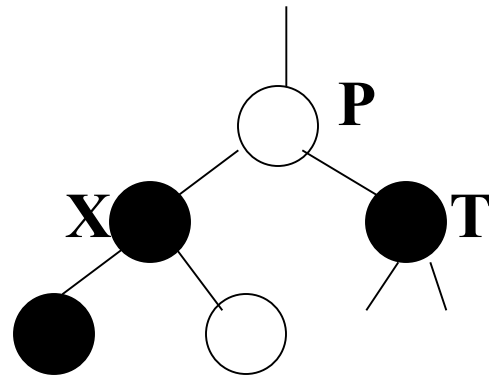

Move down the tree.

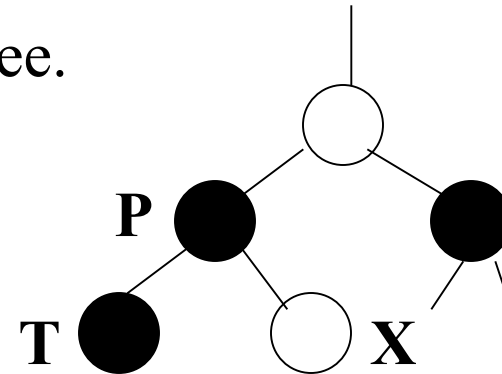
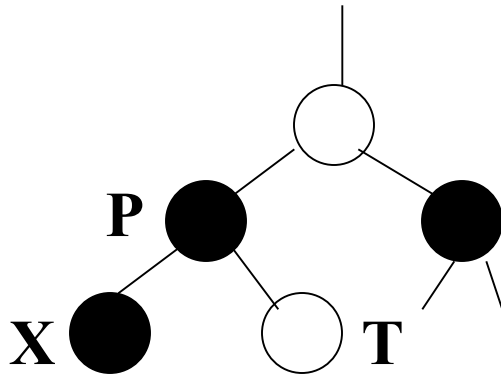

If move to Black child (2B2)
 Rotate T around P; Recolor P and T
 Back to step 2, the main case

If move to the Red child (2B1)
 Move down again

Step 3

Eventually, find the node to be deleted – a leaf or a node with one non-null child that is a leaf.

Delete the appropriate node as a Red leaf

Step 4

Color the Root Black

Example 1

Delete 10 from this RB Tree

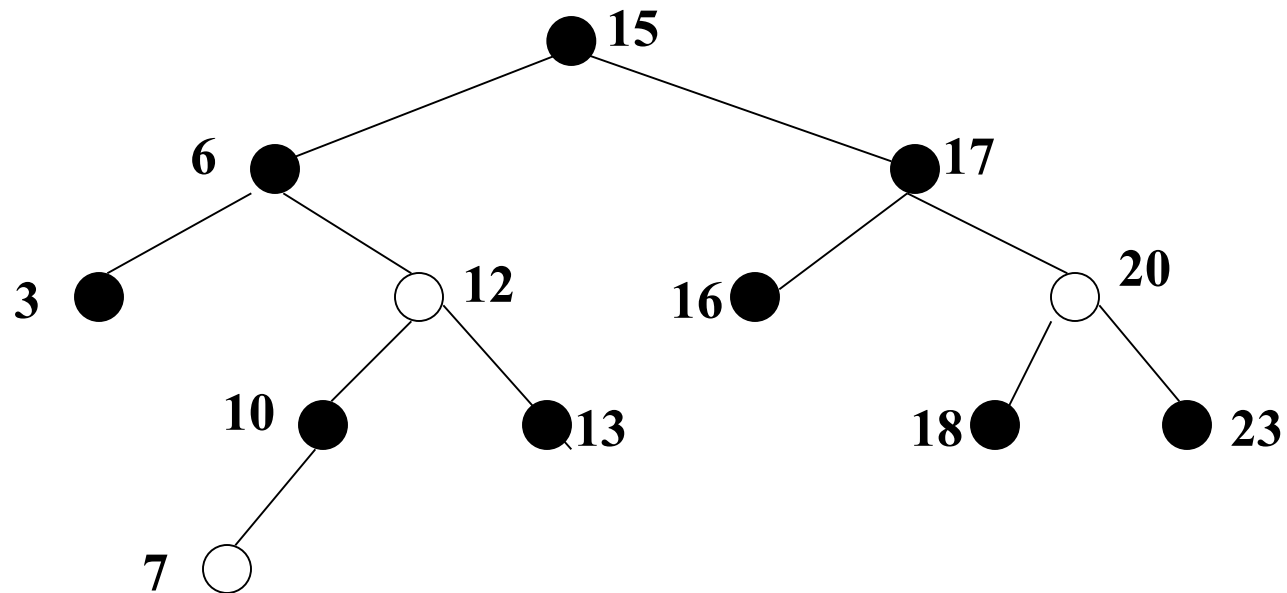

Step 1 – Root has 2 Black children. Color Root Red

Descend the tree, moving X to 6

Example 1 (cont'd)

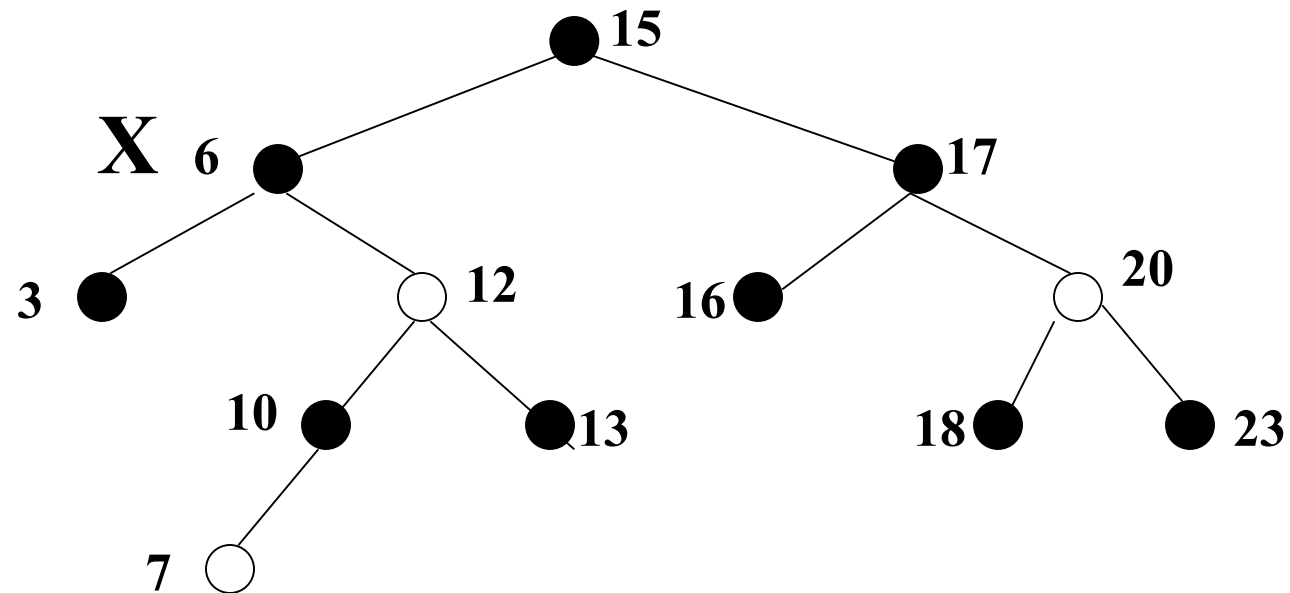

One of X's children is Red (case 2B). Descend down the tree, arriving at 12. Since the new X (12) is also Red (2B1), continue down the tree, arriving at 10.

Example 1 (cont'd)

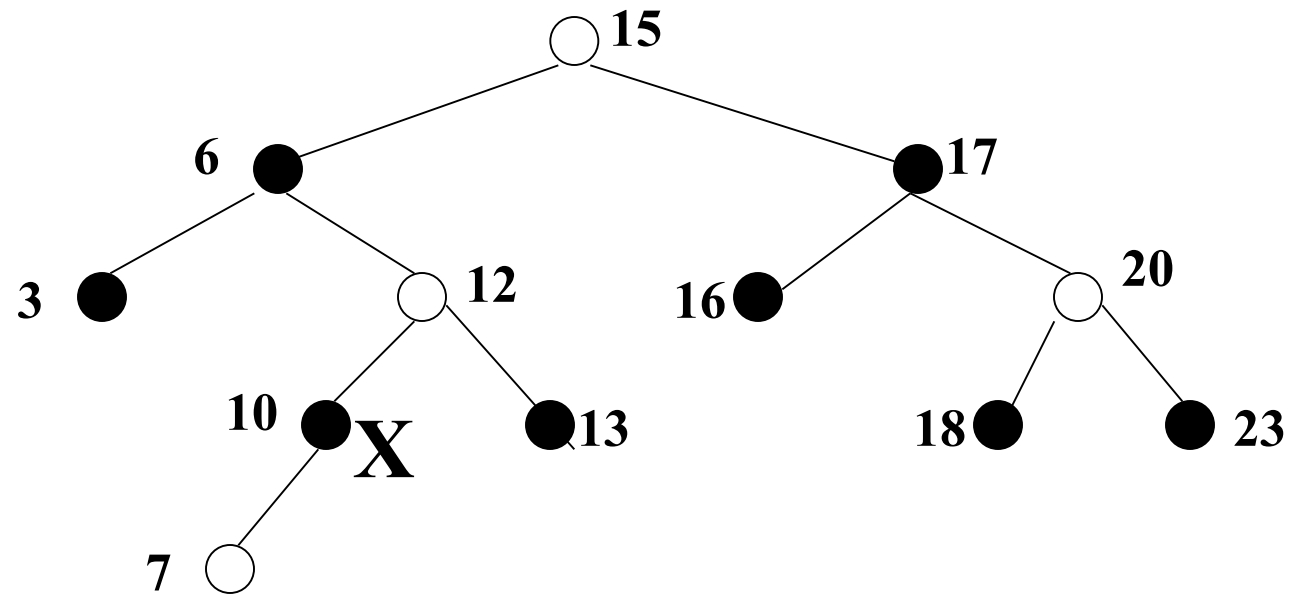

Step 3 -Since 10 is the node to be deleted, replace it's value with the value of it's only child (7) and delete 7's red node

Example 1 (cont'd)

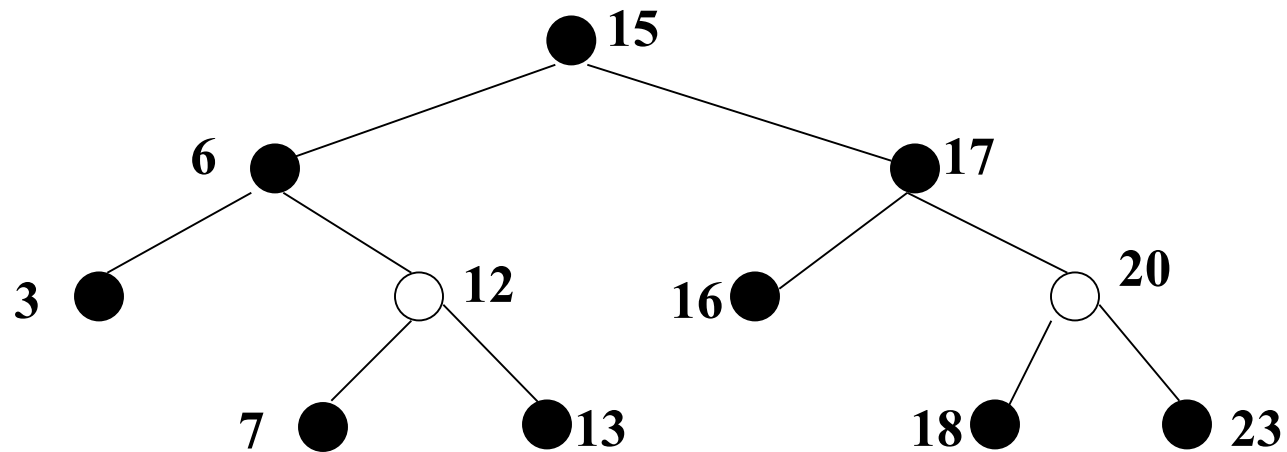

The final tree after 7 has replaced 10 and 7's red node deleted and (step 4) the root has been colored Black.

Example 2

Delete 10 from this RB Tree

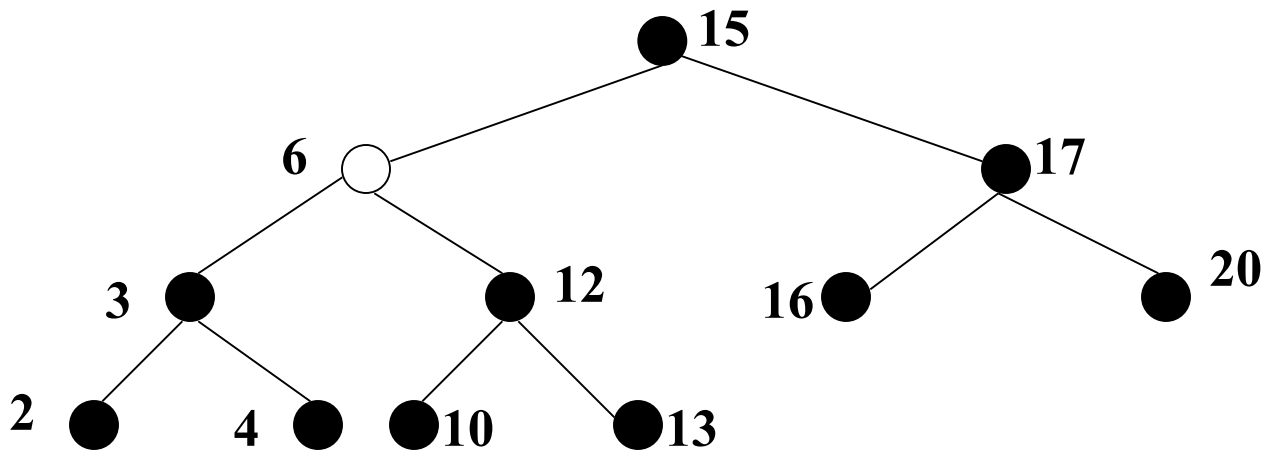

Step 1 – the root does not have 2 Black children.

Color the root red, Set X = root and proceed to step 2

Example 2 (cont'd)

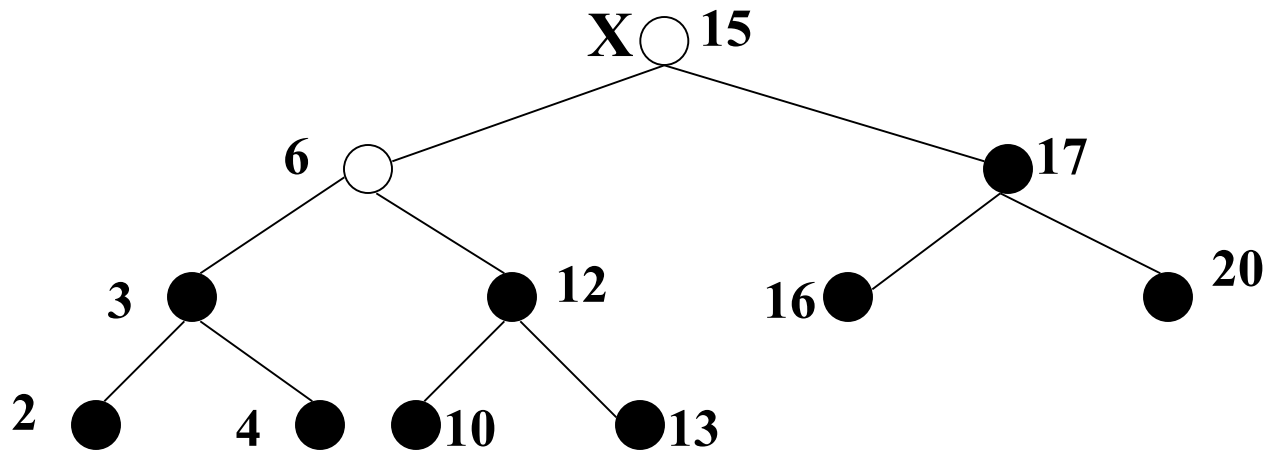

X has at least one Red child (case 2B). Proceed down the tree, arriving at 6. Since 6 is also Red (case 2B1), continue down the tree, arriving at 12.

Example 2 (cont'd)

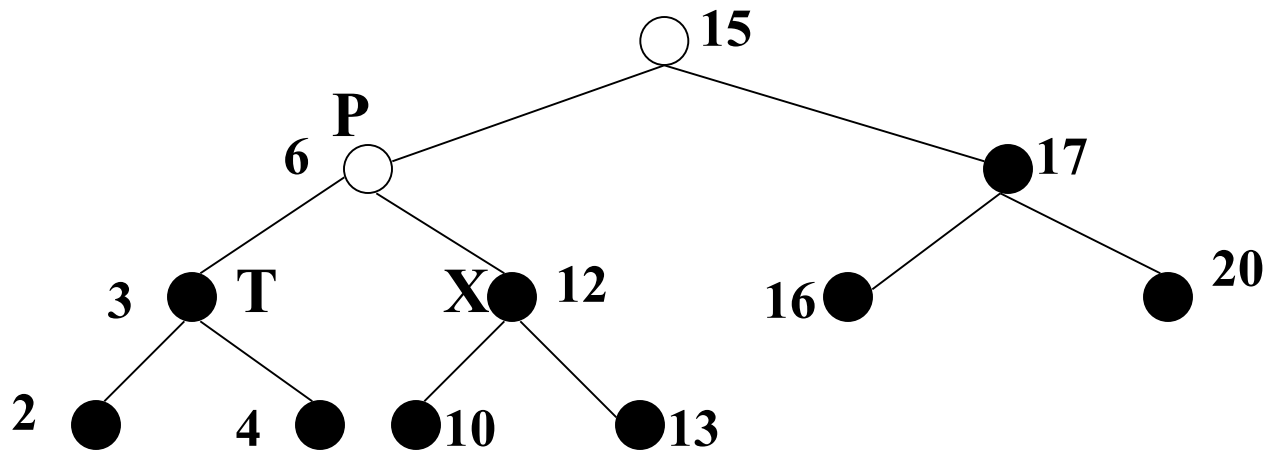

X has 2 Black children. X's sibling (3) also has 2 black children.
Case 2A1—recolor X, P, and T and continue down the tree, arriving at 10.

Example 2 (cont'd)

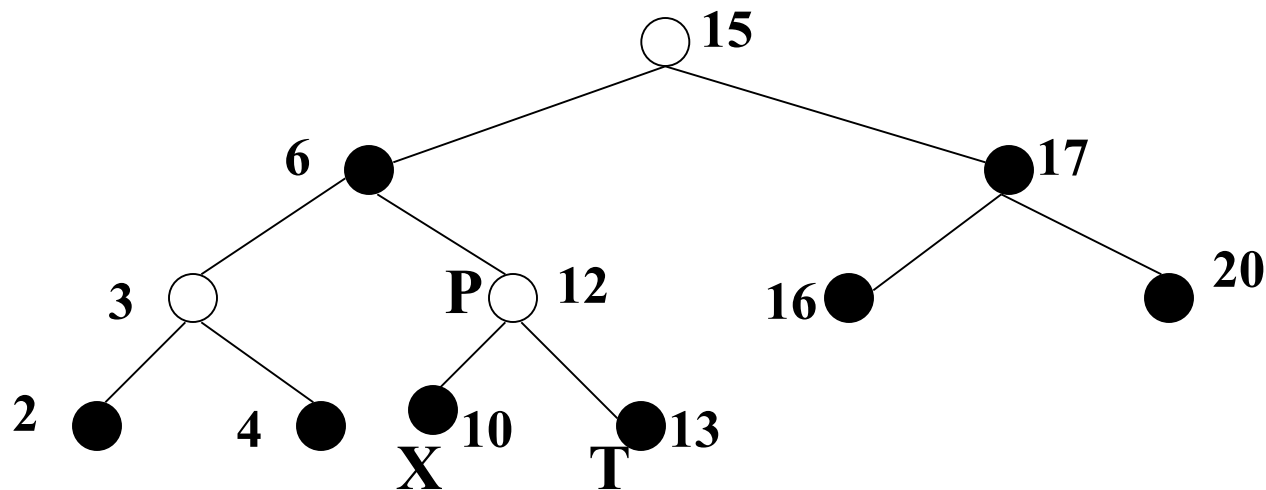

X is now the leaf to be deleted, but it's Black, so back to step 2.
X has 2 Black children and T has 2 Black children – case 2A1

Recolor X, P and T.

Step 3 -- Now delete 10 as a red leaf.

Step 4 -- Recolor the root black

Example 2 Solution

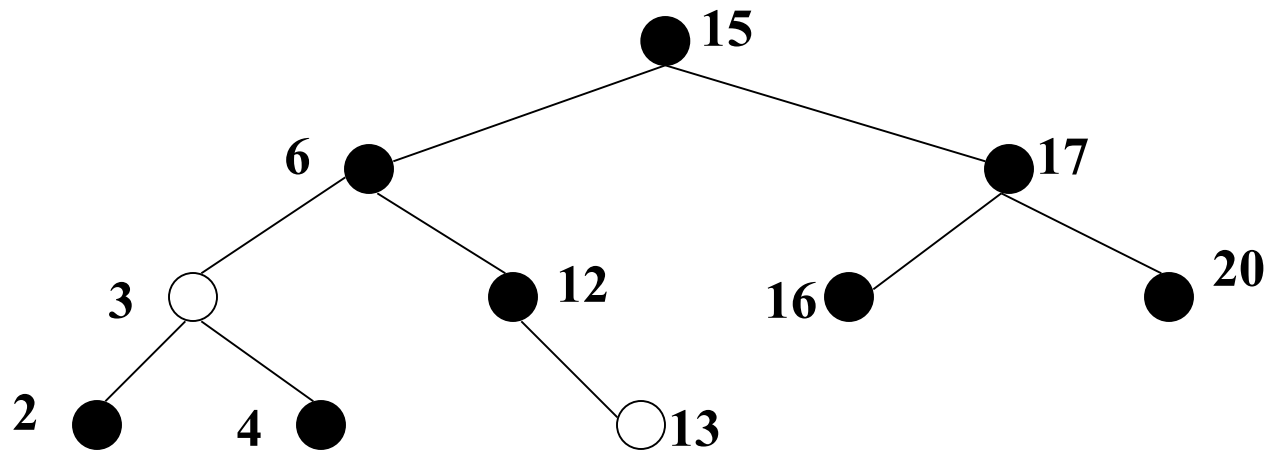

Example 3

Delete 11 from this RB Tree

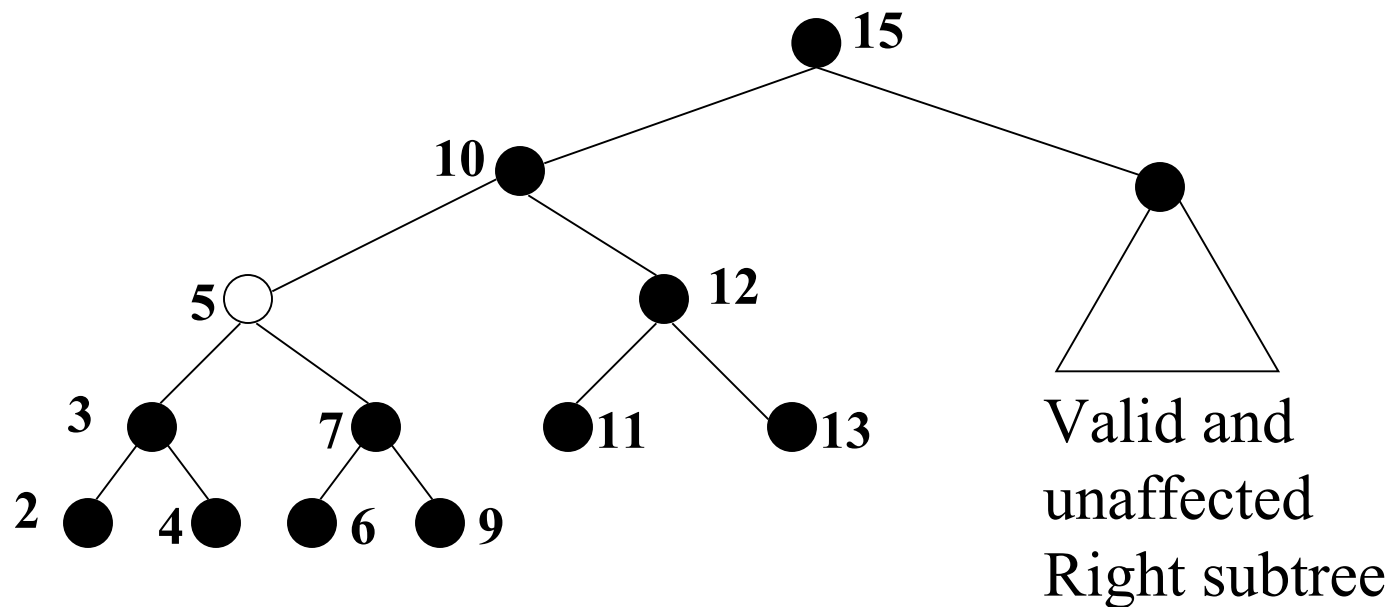

Step 1 – root has 2 Black children. Color Root red.

Set X to appropriate child of root (10)

Example 3 (cont'd)

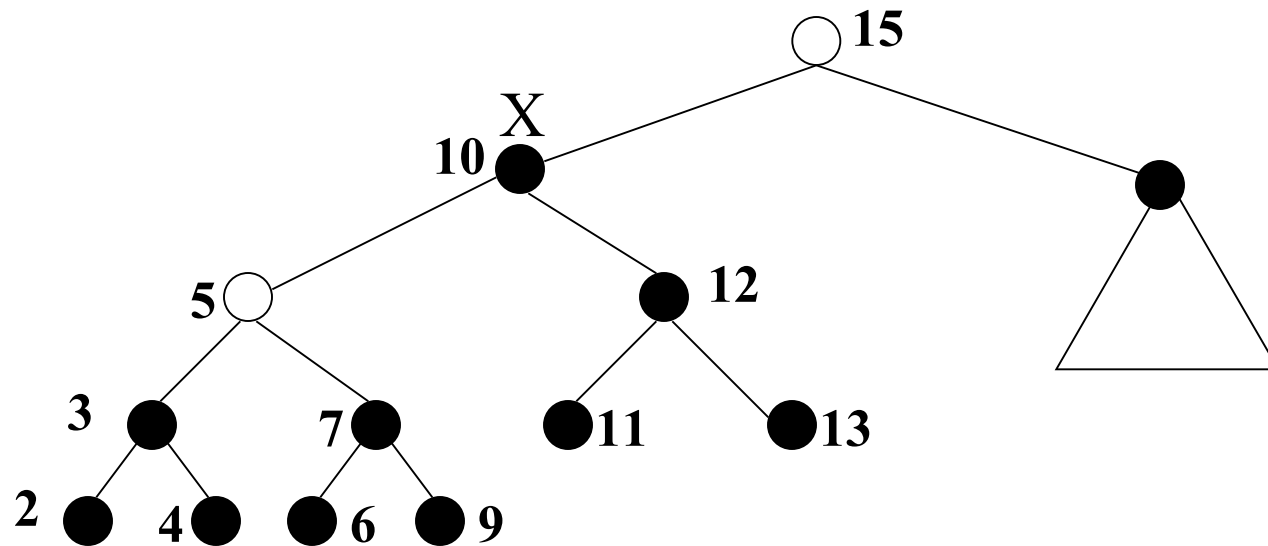

X has one Red child (case 2B)

Traverse down the tree, arriving at 12.

Example 3 (cont'd)

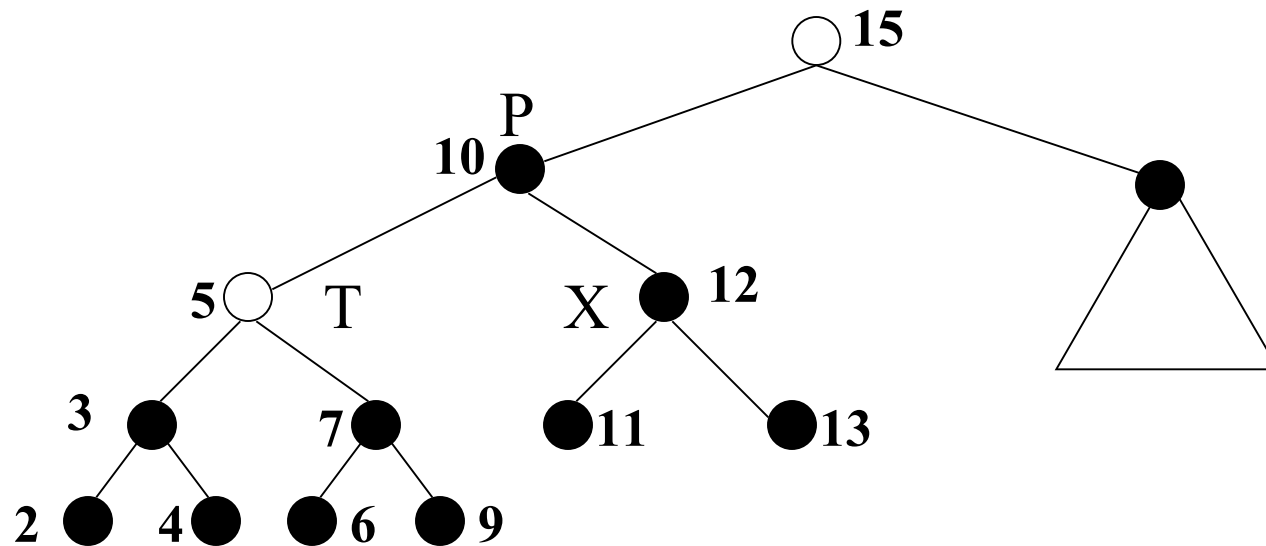

Since we arrived at a black node (case 2B2) assuring T is red and P is black), rotate T around P, recolor T and P

Back to step 2

Example 3 (cont'd)

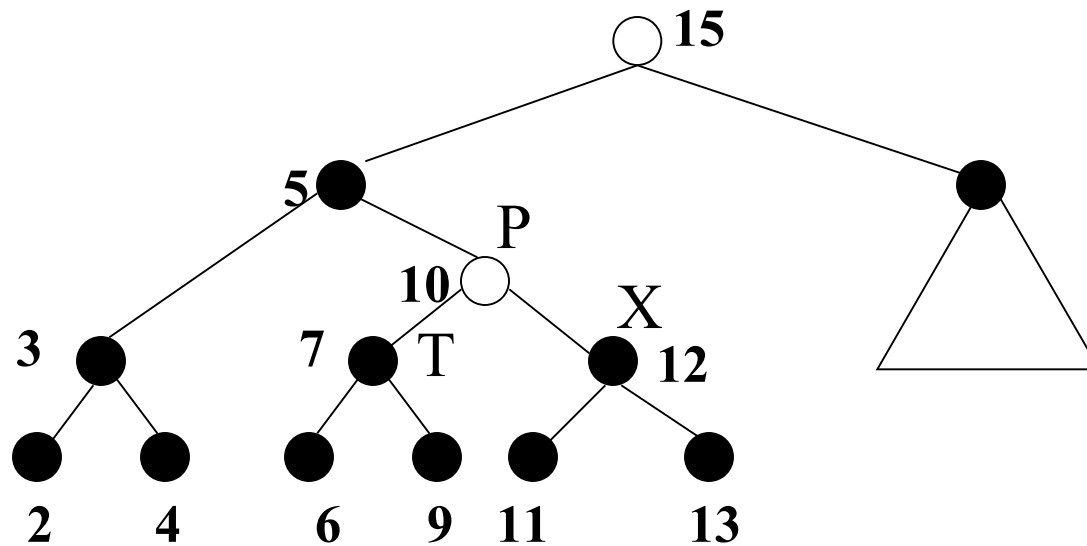

Now X is Black with Red parent and Black sibling.
X and T both have 2 Black children (case 2A1)
Just recolor X, P and T and continue traversal

Example 3 (cont'd)

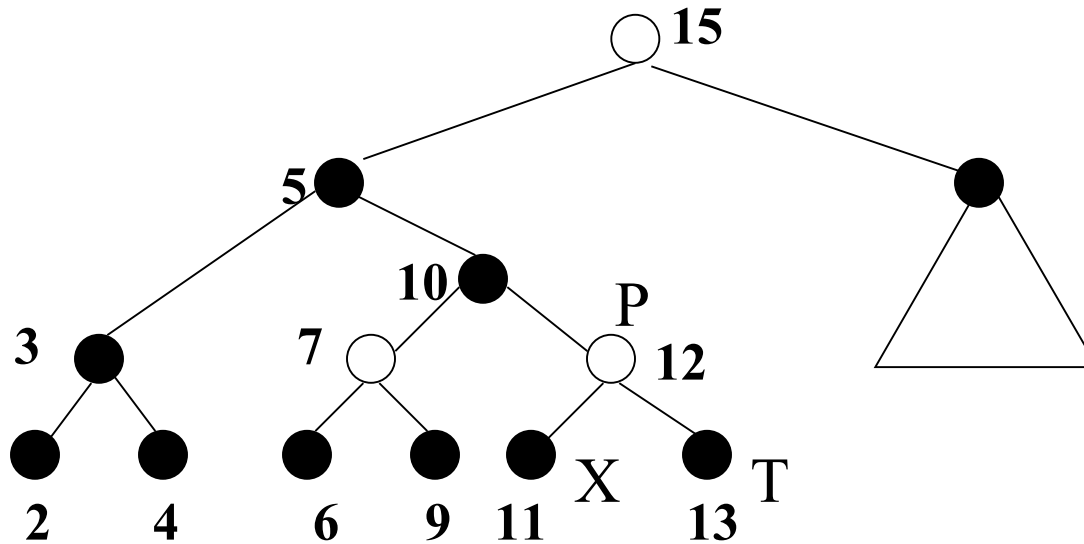

Having traversed down the tree, we arrive at 11, the leaf to be deleted, but it's Black, so back to step 2.

X and T both have two Black children. Recolor X, P and T.

Step 3 -- delete 11 as a red leaf.

Step 4 -- Recolor the root black

Example 3 Solution

