

{JSON}

**The Fat-Free Alternative to XML**

# JSON as an XML Alternative

- JSON is a light-weight alternative to XML for data-interchange
- JSON = JavaScript Object Notation
  - It's really language independent
  - Most programming languages can easily read it and instantiate objects or some other data structure
- Defined in [RFC 4627](#), IETF, July 2006
  - Current version is [RFC 8259](#), December 2017
- <http://json.org/> has more information

# JSON TL;DR

- Lightweight data-interchange format
- Easy for humans to read and write
- Easy for machines to parse and generate
- Not tied tied to Javascript or Web

# Example

```
{ "firstName": "John",  
  "lastName" : "Smith",  
  "age"      : 25,  
  "address"  :  
    { "streetAdr" : "21 2nd Street",  
      "city"      : "New York",  
      "state"     : "NY",  
      "zip"       : "10021"},  
  "phoneNumber":  
    [ { "type" : "home",  
        "number": "212-555-1234"},  
      { "type" : "fax",  
        "number" : "646-555-4567"} ]  
}
```

- This is a JSON object with five **key-value pairs**
- Objects are wrapped by curly braces
- There are no object IDs
- Keys are strings
- Values are numbers, strings, objects or arrays
- Arrays/lists are wrapped by square brackets

# Simple BNF

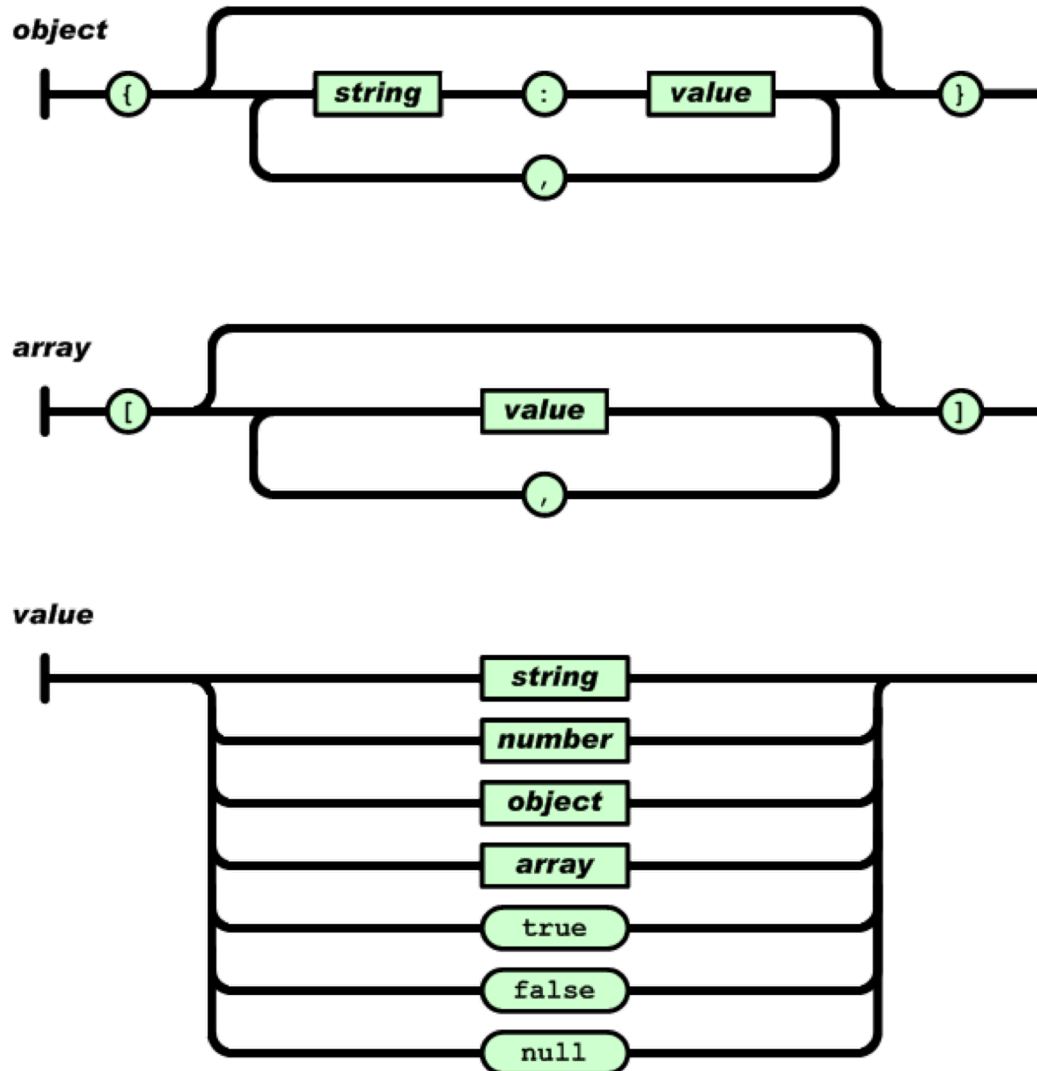

# Evaluation

- JSON is simpler and more compact than XML
  - No closing tags
  - XML parsing is hard because of its complexity
  - Compressed the two are similar in size
- JSON has a better fit for OO systems than XML
- JSON is not as extensible as XML
- Preferred for simple data exchange by many
- Less syntax, no semantics
- Schemas? We don't need no stinkin schemas!\*
- Transforms? Write your own

# JSON Schema

- <https://json-schema.org/>
- [IETF draft](#), 3/2018
- Provide annotations
- Specifies
  - Possible properties
  - Required properties
  - Value types
  - Value constraints
  - References

```
{  
  "latitude": 48.858093,  
  "longitude": 2.294694  
}
```

```
{ "id": "http://ex.com/geo-location.schema.json",  
  "$schema": "http://json-schema.org/draft-  
07/schema#",  
  "title": "Longitude and Latitude Values",  
  "description": "A geographical coordinate.",  
  "required": [  
    "latitude",  
    "longitude" ],  
  "type": "object",  
  "properties": {  
    "latitude": {  
      "type": "number",  
      "minimum": -90,  
      "maximum": 90 },  
    "longitude": {  
      "type": "number",  
      "minimum": -180,  
      "maximum": 180 }  
  }  
}
```

# JSON-LD

JSON-LD is a W3C recommendation for representing RDF data as JSON objects

```
{ "@context": {  
  "name": "http://xmlns.com/foaf/0.1/name",  
  "homepage": {  
    "@id": "http://xmlns.com/foaf/0.1/workplaceHomepage",  
    "@type": "@id"  
  },  
  "Person": "http://xmlns.com/foaf/0.1/Person"  
},  
"@id": "http://me.markus-lanthaler.com",  
"@type": "Person",  
"name": "Markus Lanthaler",  
"homepage": "http://www.tugraz.at/"  
}
```



# Many popular systems use JSON

- [MongoDB](#) is an open-source database for JSON objects
  - Very popular [NoSQL](#) database
  - A NoSQL DB is one that uses a model not based on relational tables
- [Elastic Search](#) is a popular, scalable information retrieval engine that uses JSON as its native representation

# Example: JSON in Python

```
>>> import json
>>> x = json.load(open('example.json'))
>>> x
{'lastName': u'Smith', u'age': 25, u'phoneNumber': [{u'type': u'home',
u'number': u'212-555-1234'}, {u'type': u'fax', u'number': u'646-555-4567'}],
u'firstName': u'John', u'address': {u'streetAdr': u'21 2nd Street', u'state':
u'NY', u'zip': u'10021', u'city': u'New York'}}
>>> x['address']['state']
u'NY'
>>> print json.dumps(x, sort_keys=True, separators=(',', ':'), indent=2)
{"address":{"city":"New York",
"state":"NY",
"streetAdr":"21 2nd Street",
"zip":"10021"},
"age":25,
"firstName":"John",
"lastName":"Smith",
"phoneNumber":[
{ "number":"212-555-1234",
" type":"home"},
{"number":"646-555-4567",
" type":"fax" } ] }
```

- Python's JSON package reads & writes JSON from/to files & strings
- Maps JSON objects to Python dictionaries
- Maps JSON arrays to Python lists
- Dump (write to file) and dumps (write to string) functions can do simple pretty printing

# JSON vs. XML

- JSON: The Fat-Free Alternative to XML

json.org page laying out the case for JSON over XML

- Stop Comparing JSON and XML

Blog post arguing that they're very different things with their own areas of applicability

- XML ↔ JSON

There are many web tools and software packages that can convert between simple xml and JSON representations, e.g.: [this one](#)

# Worse is Better?

- JSON vs. XML can be viewed as an example of “Worse is Better”
- In 1989 Dick Gabriel headed a company that had the best commercial version of Lisp
  - Lisp was considered by programming language experts to be superior to the much more popular C
  - Cf. today: Scheme vs. Python (w.r.t. mutable lists)
- Gabriel explained it as *worse is better*  
software that's limited, but simple to learn/use, and flexible, can be more popular to most users