

CMSC 341 Data Structures

Graph Review

October 26, 2010

These questions will help test your understanding of the Graph material discussed in class and in the text. These questions are only a study guide. Questions found here may be on your exam, although perhaps in a different format. Questions NOT found here may also be on your exam. The rotation diagrams for red-black trees *may* be provided with your exam. Check with your instructor.eps

1. Define the following terms:
 - (a) Graph
 - (b) Weighted Graph
 - (c) Directed Graph
 - (d) Undirected Graph
 - (e) Path
 - (f) Length of a Path
 - (g) Sparse Graph
 - (h) Dense Graph
 - (i) Connected Undirected Graph
 - (j) Weakly Connected Directed Graph
 - (k) Strongly Connected Directed Graph
 - (l) Adjacency Matrix
 - (m) Adjacency List
 - (n) Directed Acyclic Graph
 - (o) Topological Ordering
 - (p) Cycle
2. Let $G = (E, V)$ be an undirected graph. Let $v_1, v_2, v_3, \dots, v_p$ be the members of V , and let $q = |E|$ (the cardinality of E). Prove that the sum of the degrees of all the vertices is equal to $2q$.

3. Write pseudo-code for the breadth-first and depth-first traversals of an undirected graph.
4. Given the drawing of a graph, list the breadth-first and depth-first traversals of the graph.
5. Describe, in English, an adjacency matrix graph implementation. How does an adjacency matrix differ for *directed* and *undirected* graphs?
6. Describe, in English, an *adjacency list* graph implementation. How does an adjacency matrix differ for directed and undirected graphs?
7. Given the drawing of a directed or undirected graph, show its representation in an adjacency matrix or adjacency list.
8. Draw the weighted directed graph represented by the adjacency matrix below. A non-zero value at [row, column] indicates that the vertex in the row is "adjacent to" the vertex in the column:

	A	B	C	D	E
A	0	5	8	0	0
B	3	0	6	0	0
C	0	3	4	1	0
D	0	6	7	0	0
E	0	0	0	0	0

9. Given the drawing of a(n) (un)directed graph, show its representation in an adjacency list.
10. Draw the directed graph represented by the adjacency list below. Each element in a vertices' list is adjacent to the vertex.

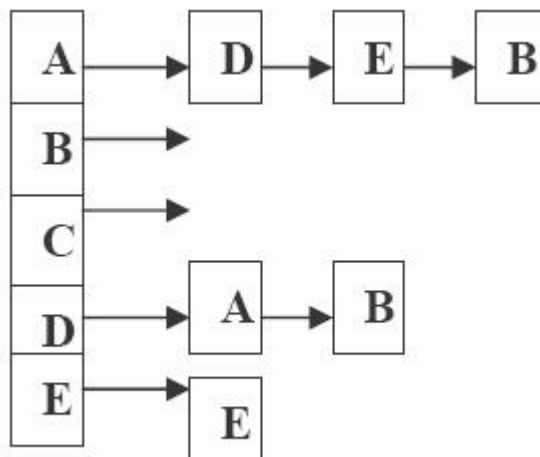

11. Given the drawing of a graph, find all cycles.
12. Discuss the characteristics of the adjacency matrix and adjacency list implementations for a graph. Include storage requirements and worst-case performance for all graph operations.
13. Given a directed graph whose edges have positive weights, use Dijkstra's algorithm to find the shortest path between a given source and destination.
14. Explain why Dijkstra's algorithm only works for graphs whose edges have positive weights.